

# Design Vehicles and Turning Radii



---

Brazhuman corp

TTE 4824

Dr. Scott Washburn



# Introduction

---

- Design vehicles are selected motor vehicles with the weight, dimensions, and operating characteristics used to establish highway design controls for accommodating vehicles of designated classes.
- For purposes of geometric design, each design vehicle has larger physical dimensions and a larger minimum turning radius than most vehicles in its class.



# Introduction

---

- The design of an intersection is significantly affected by the type of design vehicle, including horizontal and vertical alignments, lane widths, turning radii, intersection sight distance, storage length of auxiliary lanes, and acceleration and deceleration lengths on auxiliary lanes.



# Design Vehicle Classes

---

- Four general classes of vehicles have been established, namely, passenger cars, buses, trucks, and recreational vehicles.
- The passenger car class includes compacts, subcompacts, sedans, pick-up trucks, SUVs, minivans, and full-size vans.



# Design Vehicle Classes

---

- Buses include inter-city (motor coaches), city transit, school, and articulated buses.
- The truck class includes single-unit trucks, truck tractor-semitrailer combinations, and truck tractors with semitrailers in combination with full trailers.



# Design Vehicle Classes

---

- Recreational vehicles include motor homes, cars with camper trailers, cars with boat trailers, motor homes with boat trailers, and motor homes pulling cars.
- Additionally, the bicycle should also be considered a design vehicle when its use on a roadway is permitted.



# Dimensions of Design Vehicles

---

- The 2001 AASHTO Green Book includes 19 design vehicles.
- The dimensions of design vehicles take into account dimensional trends in motor vehicle manufacture and represent a composite of the vehicles currently in operation; however, the design vehicle dimensions must represent the values critical to geometric design and are thus greater than nearly all vehicles belonging to the corresponding vehicle classes.

# Design Vehicle Dimensions

AASHTO,  
 Exhibit 2-1

Design Vehicle Type	Symbol	Overall		
		Height	Width	Length
Passenger Car	P	4.25	7	19
Single Unit Truck	SU	11-13.5	8.0	30
<b>Buses</b>				
Inter-city Bus (Motor Coaches)	BUS-40	12.0	8.5	40
	BUS-45	12.0	8.5	45
City Transit Bus	CITY-BUS	10.5	8.5	40
Conventional School Bus (65 pass.)	S-BUS 36	10.5	8.0	35.8
Large School Bus (84 pass.)	S-BUS 40	10.5	8.0	40
Articulated Bus	A-BUS	11.0	8.5	60
<b>Trucks</b>				
Intermediate Semitrailer	WB-40	13.5	8.0	45.5
Intermediate Semitrailer	WB-50	13.5	8.5	55
Interstate Semitrailer	WB-62*	13.5	8.5	68.5
Interstate Semitrailer	WB-65** or WB-67	13.5	8.5	73.5
"Double-Bottom"-Semitrailer/Trailer	WB-67D	13.5	8.5	73.3
Triple-Semitrailer/ Trailers	WB-100T	13.5	8.5	104.8
Turnpike Double-Semitrailer/Trailer	WB-109D*	13.5	8.5	114
<b>Recreational Vehicles</b>				
Motor Home	MH	12	8	30
Car and Camper Trailer	P/T	10	8	48.7
Car and Boat Trailer	P/B	–	8	42
Motor Home and Boat Trailer	MH/B	12	8	53
Farm Tractor <sup>1</sup>	TR	10	8-10	16 <sup>11</sup>



# Choice of Design Vehicle

---

- The choice of design vehicle is influenced by the functional classification of a roadway, and by the proportions of the various types and sizes of vehicles expected to use the facility.
- On rural facilities, to accommodate truck traffic, one of the semitrailer combination trucks should be considered in design.
- In urban areas that are highly built-up, intersections may be designed to provide fully for passenger vehicles but require the larger vehicles to swing wide upon turning.



# Choice of Design Vehicle

---

- The vehicle which occurs with considerable frequency is often selected as the design vehicle.
- The largest of all the several design vehicles are usually accommodated in the design of freeways, subject to state laws on permitted vehicles.



# Turning Radii

---

- The principal dimensions affecting design are the minimum centerline turning radius, the wheelbase, and the path of the inner rear tire.
- Effects of driver characteristics (such as the speed at which the driver makes a turn) and the slip angles of wheels are minimized by assuming that the speed of the vehicle for the minimum radius (sharpest) turn is 10 mph (15 km/h) or less.



# Turning Radii

---

- The boundaries of the turning paths of the several design vehicles when making the sharpest turns are established by the outer trace of the front overhang and the path of the inner rear wheel.
- This turn assumes that the outer front wheel follows the circular arc defining the minimum turning radius as determined by the vehicle steering mechanism.

# Turning Characteristics

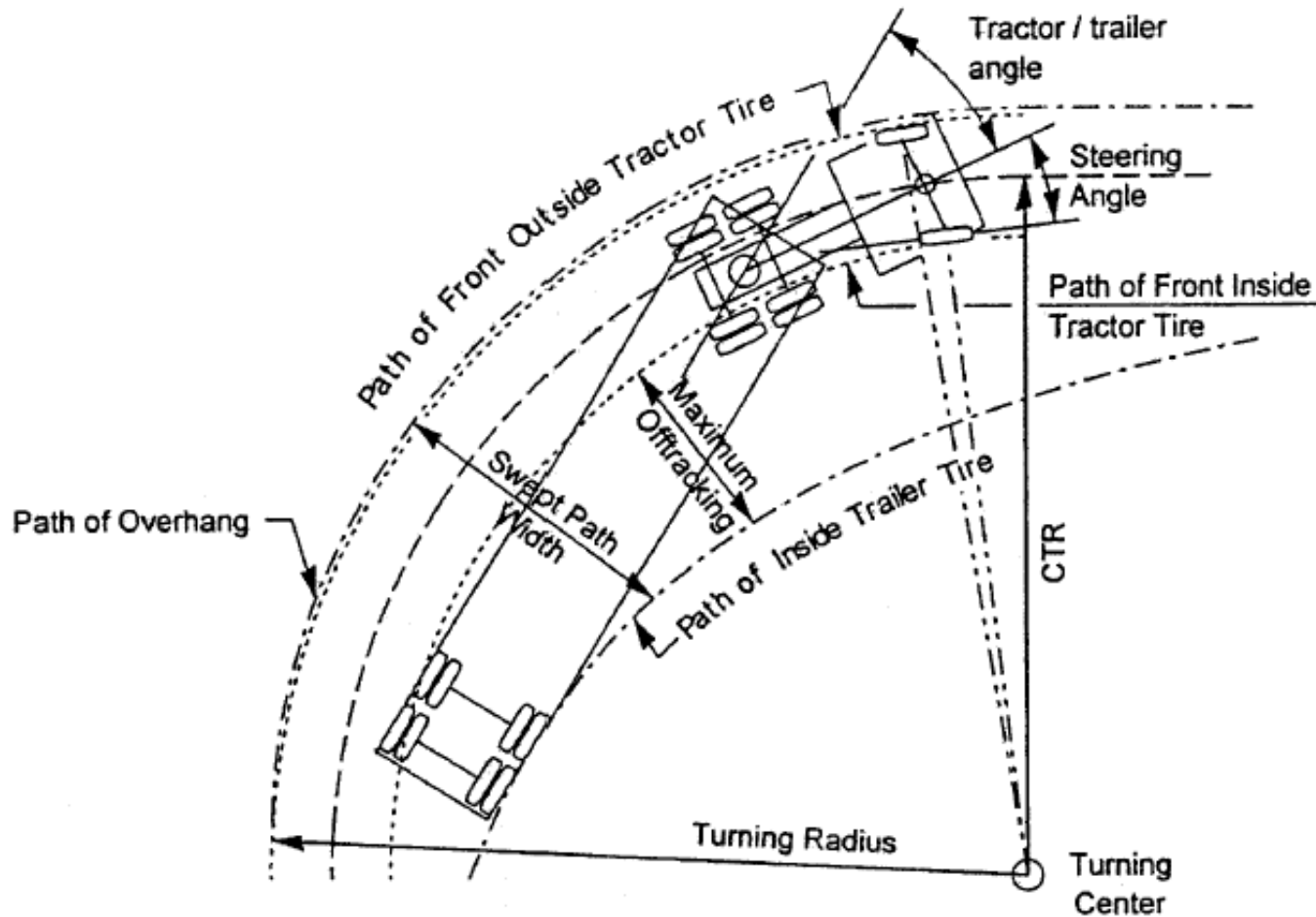



# Definitions

---

1. Turning radius—The circular arc formed by the turning path radius of the front outside tire of a vehicle. This radius is also described by vehicle manufacturers as the “turning curb radius.”
2. CTR—The turning radius of the centerline of the front axle of a vehicle.
3. Offtracking—The difference in the paths of the front and rear wheels of a tractor/semitrailer as it negotiates a turn. The path of the rear tires of a turning truck does not coincide with that of the front tires, and this effect is shown in the drawing above.
4. Swept path width—The amount of roadway width that a truck covers in negotiating a turn and is equal to the amount of offtracking plus the width of the tractor unit. The most significant dimension affecting the swept path width of a tractor/semitrailer is the distance from the kingpin to the rear trailer axle or axles. The greater this distance is, the greater the swept path width.
5. Steering angle—The maximum angle of turn built into the steering mechanism of the front wheels of a vehicle. This maximum angle controls the minimum turning radius of the vehicle.
6. Tractor/trailer angle—The angle between adjoining units of a tractor/semitrailer when the combination unit is placed into a turn; this angle is measured between the longitudinal axes of the tractor and trailer as the vehicle turns. The maximum tractor/trailer angle occurs when a vehicle makes a 180° turn at the minimum turning radius; this angle is reached slightly beyond the point where maximum swept path width is achieved.



# Turning Radii

---

- Geometric design for trucks and buses require much more generous designs than for passenger vehicles.
- Trucks and buses are wider and have longer wheelbases and greater minimum turning radii. These are the principal characteristic dimensions affecting horizontal roadway design.
- The longer single-unit trucks and buses require greater minimum turning radii than most vehicle combinations, but because of their greater offtracking, the longer vehicle combinations also require greater widths of turning paths.

# AASHTO Turning Templates

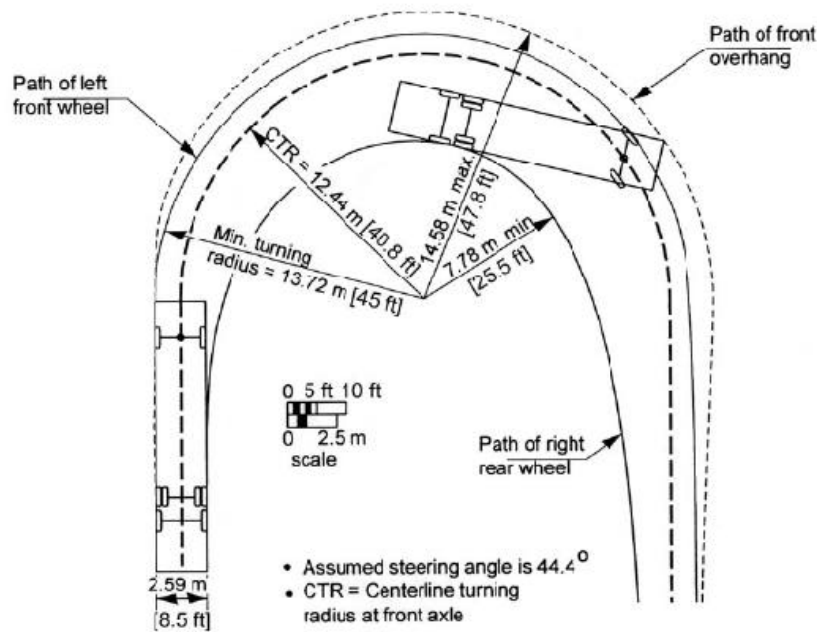

Exhibit 2-6. Minimum Turning Path for Intercity Bus (BUS-14 [BUS-45]) Design Vehicle

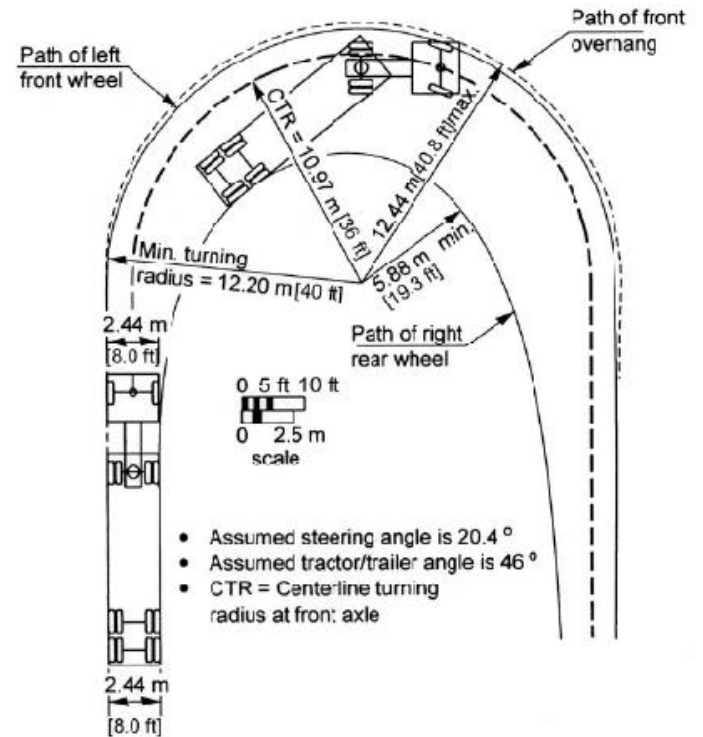
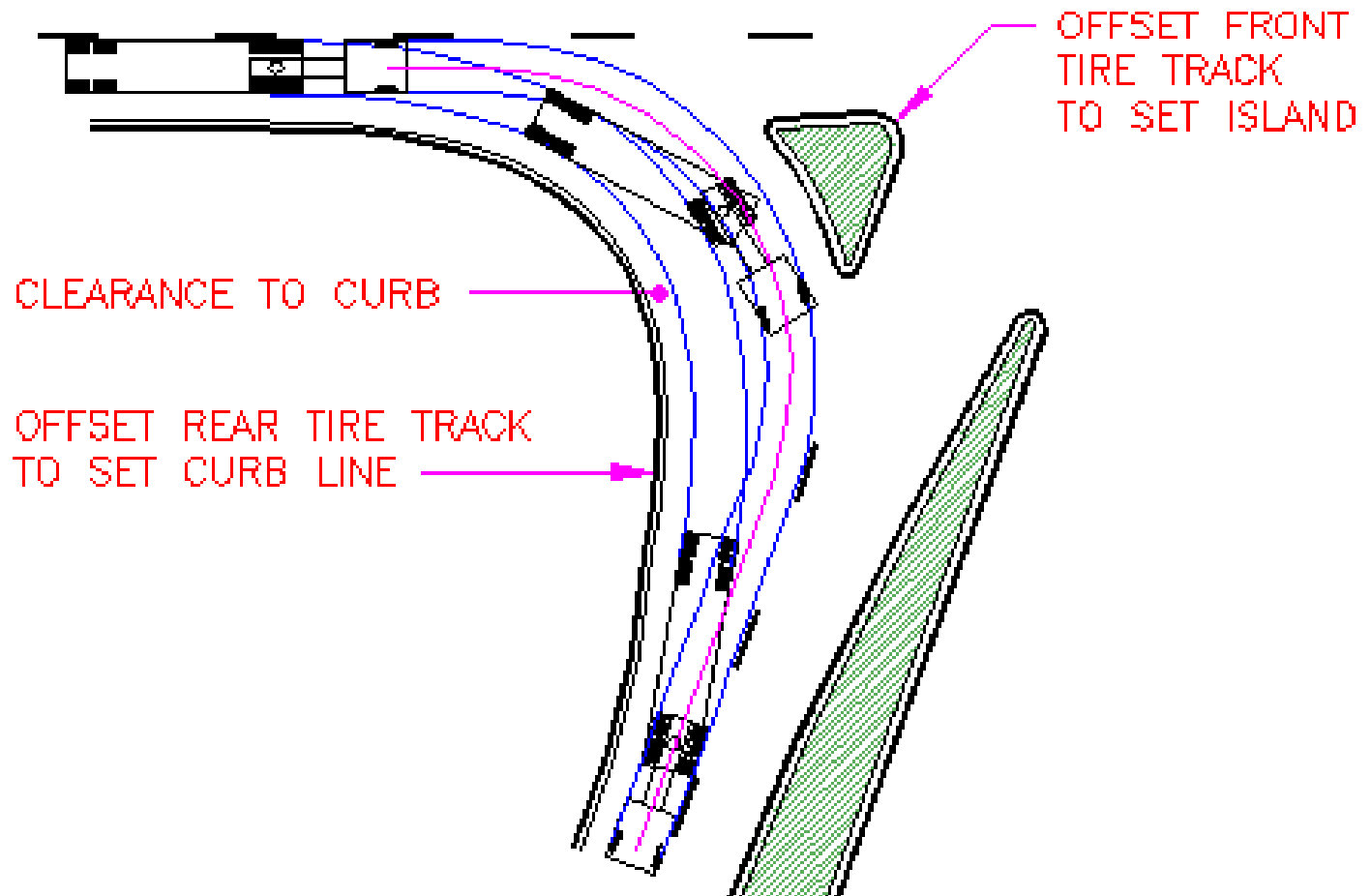
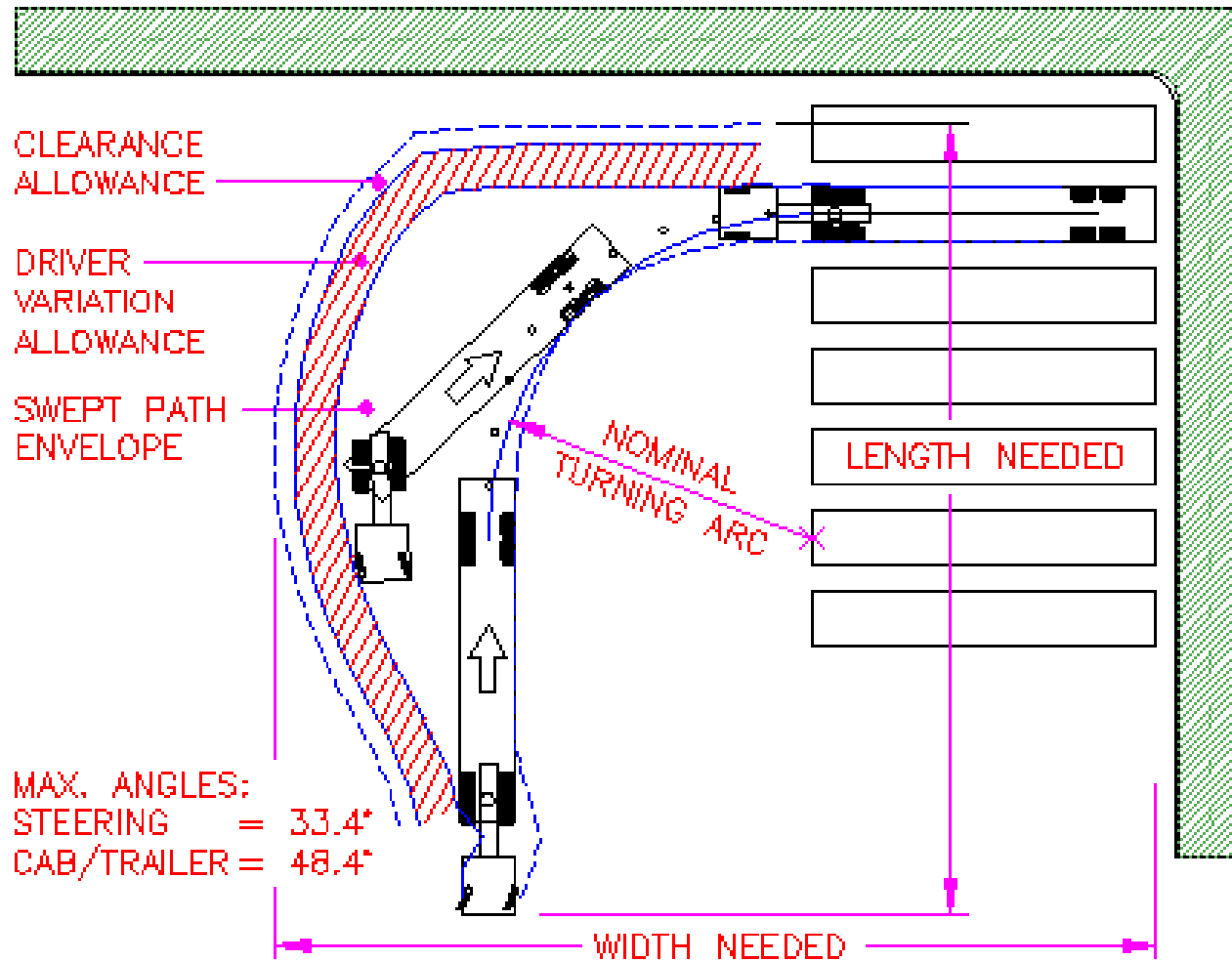

Exhibit 2-13. Minimum Turning Path for Intermediate Semitrailer (WB-12 [WB-40]) Design Vehicle

# AutoTURN Sample



# AutoTURN Sample





# Contatos:

---

brazhuman



(11) 3255-8155

[brazhuman@brazhuman.com.br](mailto:brazhuman@brazhuman.com.br)

R. Major Sertório 212 1º and cj 11  
V. Buarque São Paulo CEP 01222-000